

THIS DRAWING IS UNPUBLISHED. RELEASED FOR PUBLICATION, 19 .
 © COPYRIGHT 19 BY AMP INCORPORATED. ALL INTERNATIONAL RIGHTS RESERVED.

LOC	DIST	P	F	REVISIONS				
AF	50			ZONE	LTR	DESCRIPTION	DATE	APPD
					J	REV PER 0710-0057-95	2/16/95	JR/JW

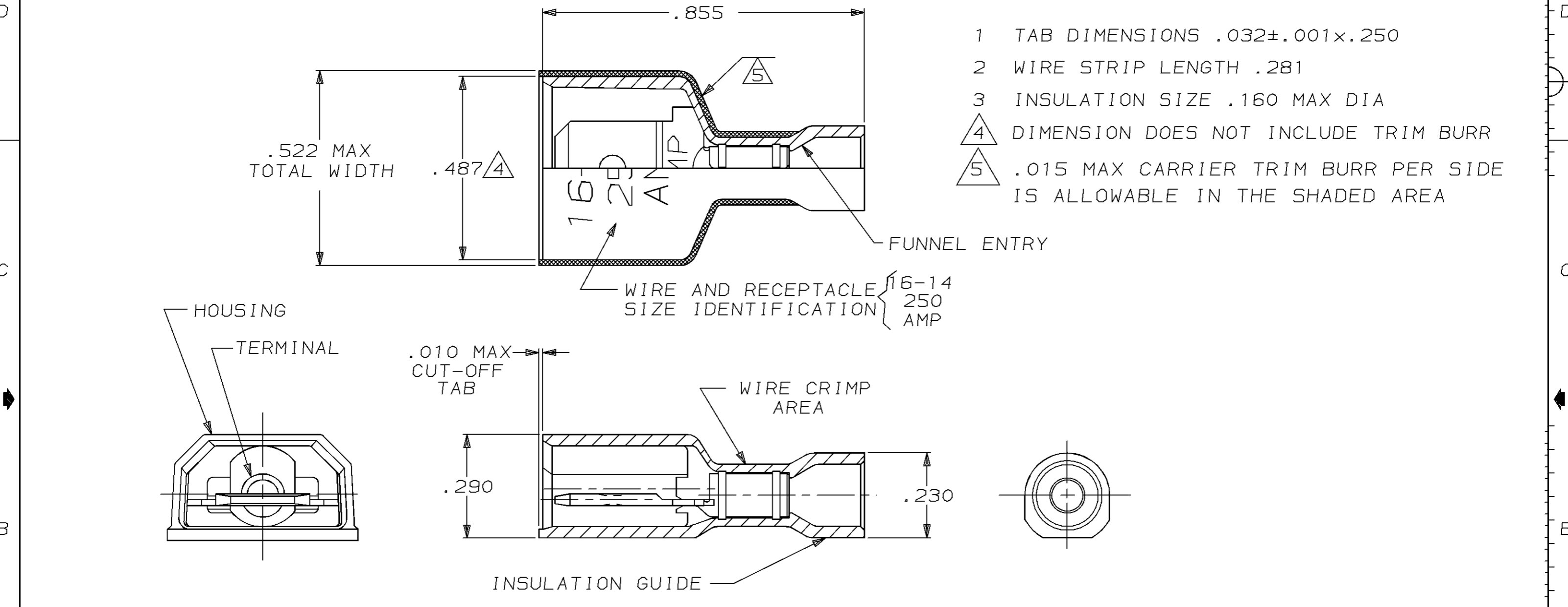

HOUSING: NYLON, COLOR-BLUE TRANSLUCENT		3-520107-2	
RECEPTACLE: #3 HARD BRASS, TIN .000080 MIN		PART NO	
MATERIAL & FINISH		AMP INCORPORATED Harrisburg, Pa. 17105	
DO NOT SCALE PRINT. UNLESS SPECIFIED DIMENSIONS IN INCHES TOLERANCES ON: 2 PLC DEC ± - 3 PLC DEC ± .015 ANGLES ± -		NAME TAB ASSEMBLY, ULTRA-FAST, LOOSE PIECE, .250 SERIES, 16-14 AWG	
MATERIAL SEE TABLE		SIZE B	
FINISH SEE TABLE		FSCM NO 00779	
DR 11/15/88 P FORTNEY CHK 11/30/88 MS FEHER APPD 12/14/88 KA RANDOLPH APPD 1/9/89 TL SHUTTER PRODUCT SPEC 108-2017 APPLICATION SPEC 114-2123 WEIGHT -		DRAWING NO 520107	
		SCALE 4:1	
		SHEET 1 OF 1	